

---

Bighands Building Supply Australia Pty Ltd  
60-68 Hampstead Road Auburn NSW 2144  
p: 1300 242 799  
e:info@bighandsbuildingsupplies.com.au  
w: bighandsbuildingsupplies.com.au

## Installation Guide

# Solid Polycarbonate



# Installation Guide

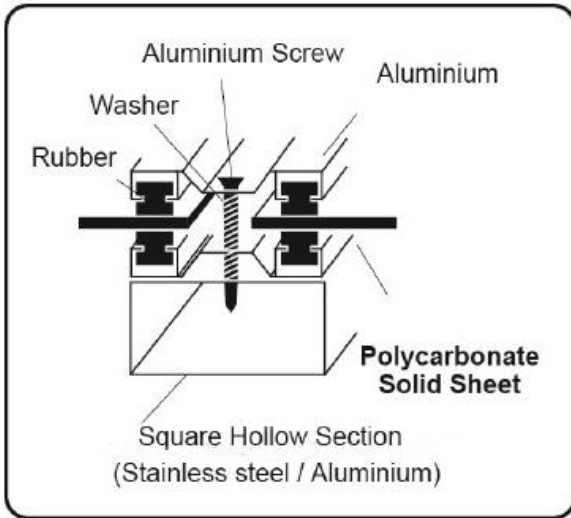

Make sure the support structure is clean and dry. Do not directly screw the sheet, only use aluminium clapping for joining. Must leave a gap of at least 5mm in between sheets for thermal expansion and contraction. A minimum slope of 5° roof pitch is recommended to allow adequate rain water run-off.

Screw Recommendation:  
1 of **SDS 12-14 35mm** screws/ meter

Use only new or sharp ground steel or carbide tipped drills. All holes must be drilled at least 40mm from the edge of the sheet. All holes must be at least 4mm bigger than screw for thermal expansion and contraction.

Screw Recommendation:  
1 of **SDS Washer 50mm**/ meter

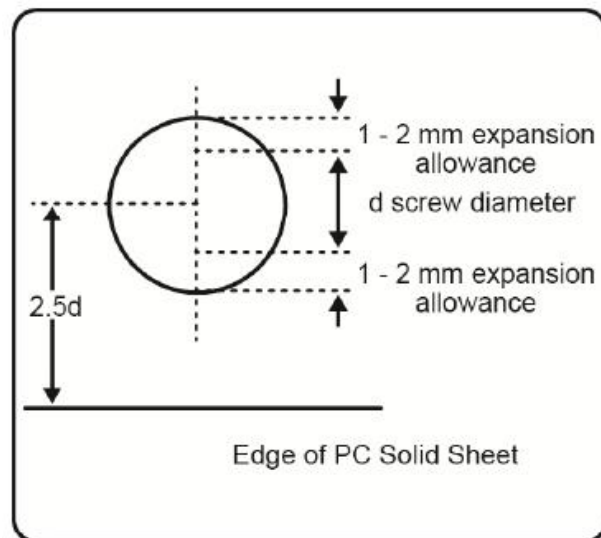
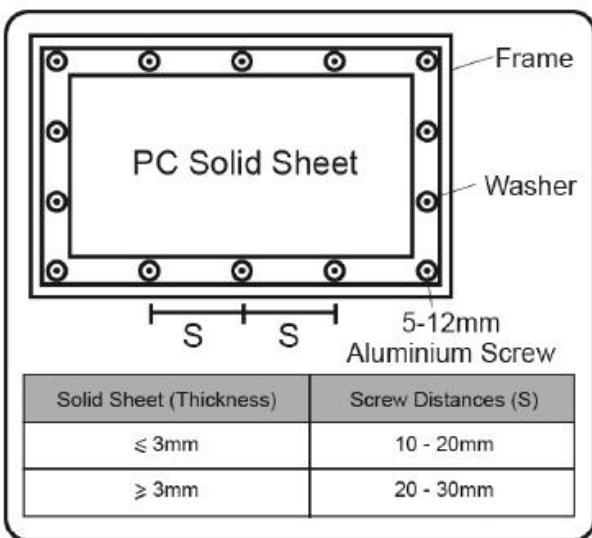
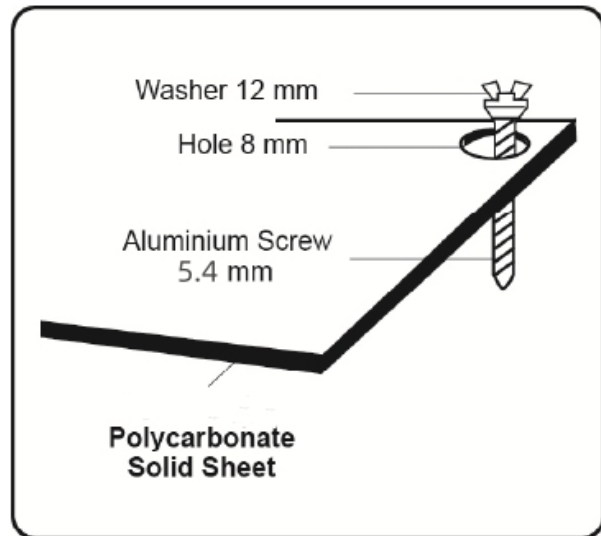

---

## Recommend Installation Method

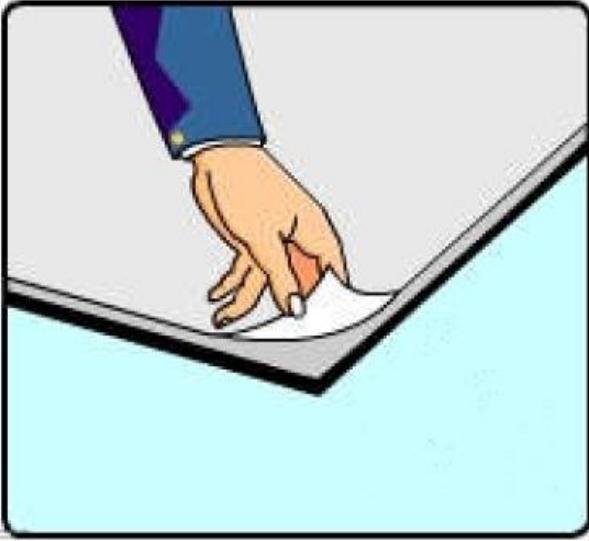

Bighands Polycarbonate Solid Sheet's is produced with a protective PE film on both sides which should be kept on until the panel is fastened. The UV protected side is to be faced towards the sun and is marked with printed film.

To install, 50mm of protective film should be peeled off from the edges of the sheet to allow clean sheet insertion into the glazing system. The residual film should be removed immediately after the glazing is completed.

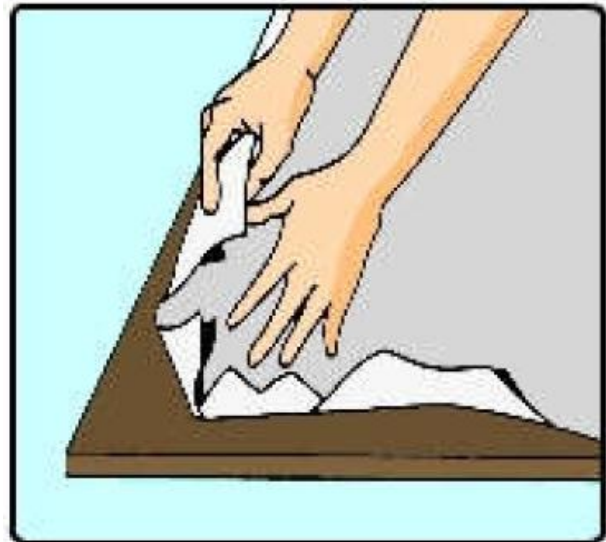

The residual film should be removed immediately after the glazing is completed.

---

## For Maintenance and Storage Guidelines

- **Storage Method**



Sheets should be kept indoor, protected from sunlight and rain fall by an appropriate opaque waterproof roof cover.

- **Cleaning Method**

Use only neutral detergent or mild soap for cleaning. Wash by using soft cloth or sponge. Rinse off with lukewarm water (below 60°C)

- **Use only neutral silicone for polycarbonate.**



Use circular saw blade for cutting Bighands Polycarbonate Solid Sheet.

---

# 10-Year Limited Warranty (Australia)

## 1. Warranty Period

Bighands Building Supply Pty Ltd (“Bighands”) warrants that its Solid Polycarbonate Sheets (“Product”) will perform in accordance with this warranty for a period of ten (10) years from the date of original purchase.

The commencement date shall be the date of manufacture or, if not identifiable, the date of purchase.

This warranty applies within Australia and to the original purchaser only.

## 2. Scope of Warranty (Performance Guarantee)

Subject to the conditions set out in this document, Bighands warrants that:

### 2.1 Light Transmission

Clear sheets will not exhibit a reduction in light transmission exceeding 6% compared to the original value, when tested in accordance with ASTM D1003 or equivalent.

### 2.2 Yellowing Resistance

Clear sheets will not exhibit a change in yellowness index exceeding  $\Delta 10$  compared to the original value, when tested in accordance with ASTM D1925 or equivalent.

### 2.3 Impact and Breakage Resistance

The Product will not fail due to excessive loss of impact strength resulting directly from weathering or normal environmental exposure.

Impact performance may be assessed using recognised standards such as ISO 6603 or ASTM D5628. Breakage is defined as brittle fracture resulting in separation of the material.

No material is unbreakable, and this warranty does not guarantee resistance to all forms of impact.

## 3. Warranty Conditions

This warranty is valid only if all of the following conditions are met:

### 3.1 Installation

The Product must be installed in accordance with Bighands installation guidelines, including:

- UV-protected surface installed facing outward (where applicable)
- Allowance for thermal expansion and contraction
- Use of compatible fixing systems and accessories

---

### 3.2 Handling and Storage

The Product must be:

- Stored in a dry and protected environment
- Protected from premature UV exposure prior to installation
- Handled to prevent scratches, abrasion, or mechanical damage

### 3.3 Use

- The Product must:
- Be used in accordance with intended applications
- Not be exposed to chemical, corrosive, or incompatible substances
- Not be thermoformed or modified unless specifically approved

### 3.4 Maintenance

The Product must be properly maintained and cleaned using suitable non-abrasive methods.

## 4. Exclusions

This warranty does not apply to:

- Incorrect installation, including:
- Incorrect UV orientation
- No allowance for thermal movement
- Damage caused by:
- Improper handling, storage, or transport
- Chemical exposure or environmental contamination
- Scratching, abrasion, or surface damage
- Accidental damage, misuse, or vandalism
- Product modification, including:
- Thermoforming or structural alteration
- Normal wear and tear
- Any application outside recommended use conditions

## 5. Claim Procedure

To make a claim under this warranty, the customer must:

Notify Bighands via email or SMS text message within 14 days of discovering the defect

- Provide:
- Proof of purchase (invoice)
- Product identification and quantity
- Description and supporting evidence of the defect
- Allow Bighands reasonable access to inspect the Product or request return samples for testing

Failure to comply may result in rejection of the claim.



---

## 6. Remedies

If a valid claim is accepted, Bighands will, at its discretion:

- Provide replacement Product; or
- Refund the original purchase price (or a proportion)

For claims made after the initial period, Bighands may apply a pro-rata adjustment based on the age of the Product.

This warranty applies to material only and excludes:

- Installation or removal costs
- Labour costs
- Transportation costs
- Any indirect or third-party costs

## 7. Limitation of Liability

To the extent permitted by law:

- Bighands shall not be liable for any indirect, incidental, or consequential loss or damage
- Bighands' liability is limited to the remedies set out in Section 6

## 8. Australian Consumer Law Notice

Our goods come with guarantees that cannot be excluded under the Australian Consumer Law.

You are entitled to:

- A replacement or refund for a major failure; and
- Compensation for any other reasonably foreseeable loss or damage

You are also entitled to have the goods repaired or replaced if the goods fail to be of acceptable quality and the failure does not amount to a major failure.

This warranty is provided in addition to your rights under the Australian Consumer Law.

## 9. Governing Law

This warranty shall be governed by the laws of Australia. Any disputes shall be subject to the jurisdiction of Australian courts.